



THE LOW LOADER RANGE

Traditional Innovation



www.langendorf.de

LANGENDORF SINCE 1956

In 1956 Langendorf launched a revolutionary concept. A trailer with access from the rear. This opened another market for Langendorf, in addition to our regular tipper trailers. History was born.

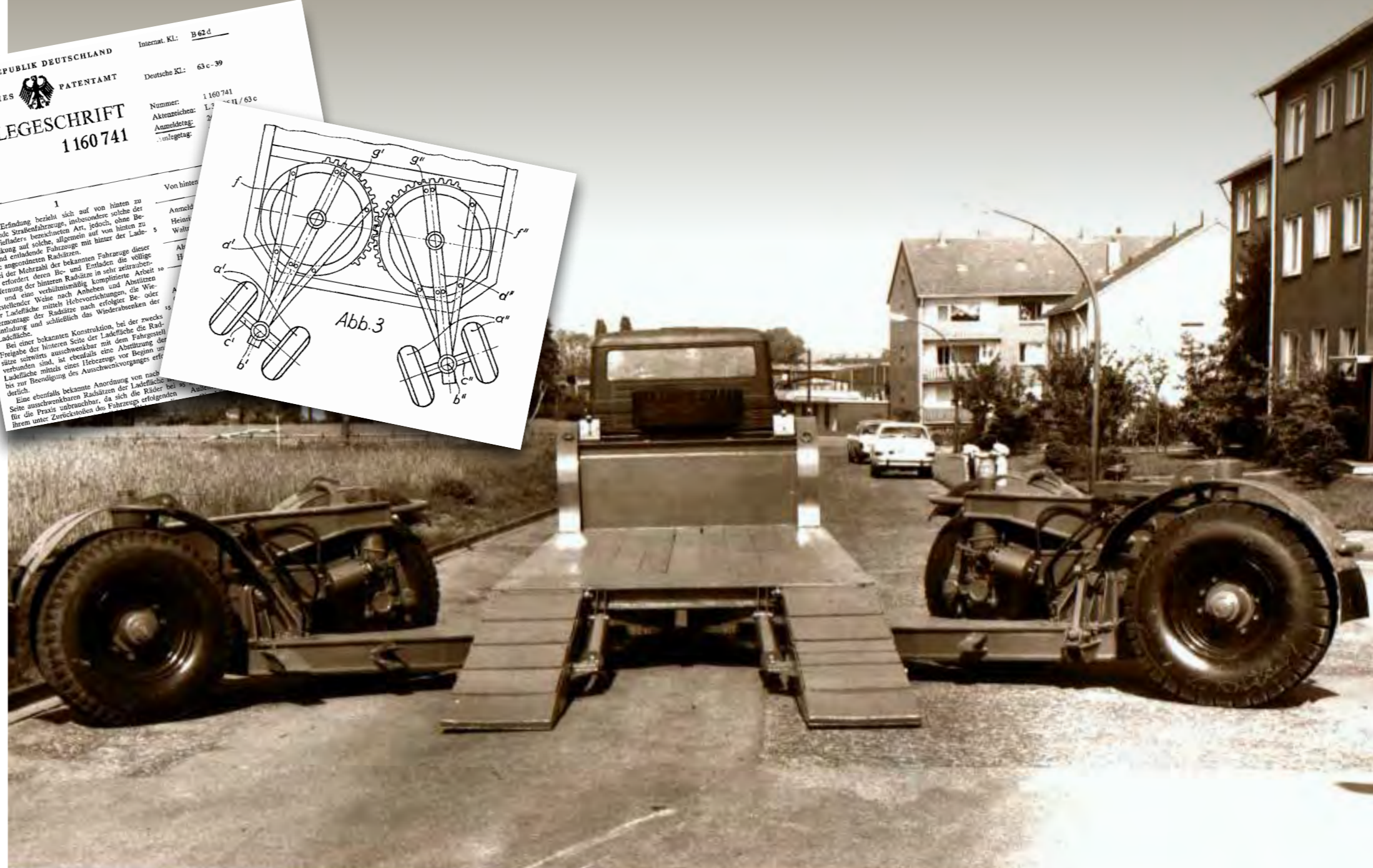

Today, Langendorf is still one of the most innovative companies in the industry. Always looking for innovation, always trying to find solutions for complex transport challenges. This commitment to building the best products for our customers is demonstrated every day.

Contents



LOW LOADER TRAILERS

- 10 SATÜ 30 and SATÜV
Low loader trailers with or without wheelboxes, extendable
- 12 SATÜ-H 30
Low loader trailer with hydraulic ramp for access equipment
- 14 SATÜ
Options
- 16 SATAH
Low loader trailers with detachable goose neck
- 18 SATAHV
Low loader trailer with detachable gooseneck, extendable
- 20 SATH
Low loader trailer with hydraulic ramp in low bed
- 22 SATHV
Low loader trailer with hydraulic ramp in low bed, extendable
- 24 SATBÜ
Low loader trailer with wedges in low bed
- 26 SATBÜV
Low loader trailer with wedges in low bed, extendable
- 28 Low loader trailer for agricultural machines
- 30 Ramps
- 32 Options and accessories

MY LANGENDORF

TRADITIONAL INNOVATION



The name Langendorf is recognised internationally as one of the most renowned manufacturers of commercial vehicle bodies and trailers, tracing its roots back for more than 125 years. Langendorf serves customers both in the domestic market and in the export market. This naturally makes us very proud as well as forming a commitment with the industry, and our customers.

Our product range includes:

- Tipper semi-trailers with aluminium or steel bodies
- Tipper bodies for rigid trucks
- Glass, concrete and double-deck inloaders
- Low loader semi-trailers
- Special trailers



SATÜ 30 AND SATÜV

THE LOW LOADER TRAILERS WITH AND WITHOUT WHEELBOXES

These trailers can also be delivered with power-steered axle.



SATÜ 30

Compact, easy manoeuvring, suited for many purposes.

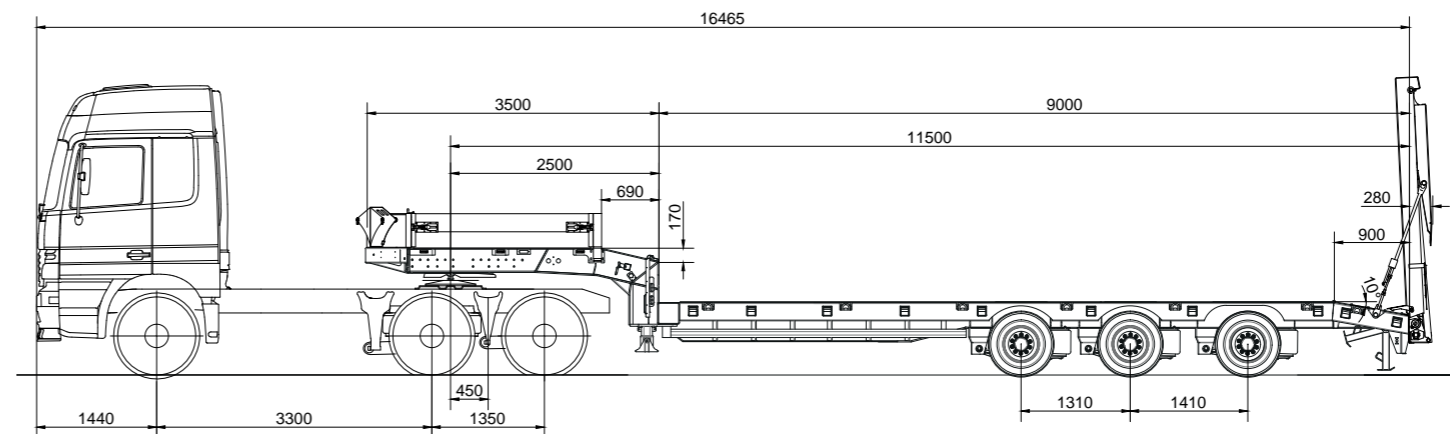

SATÜ 30 WITH WHEELBOXES

Multi-purpose trailer with wheelboxes for wheeled machinery.

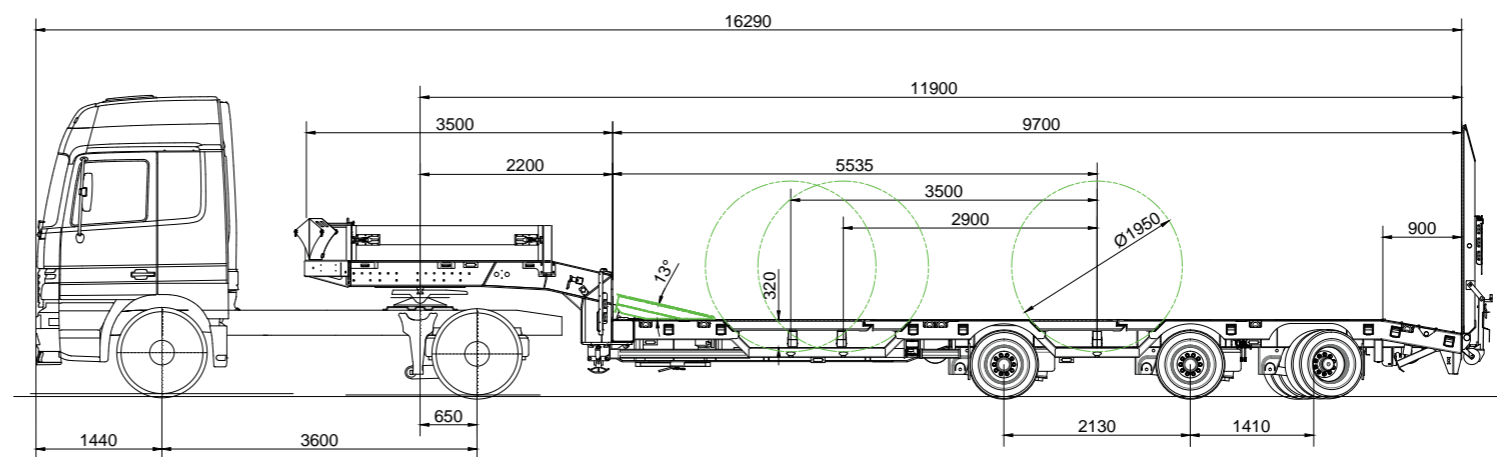

SATÜV 40

Including a 4th axle and available as an extendable version.

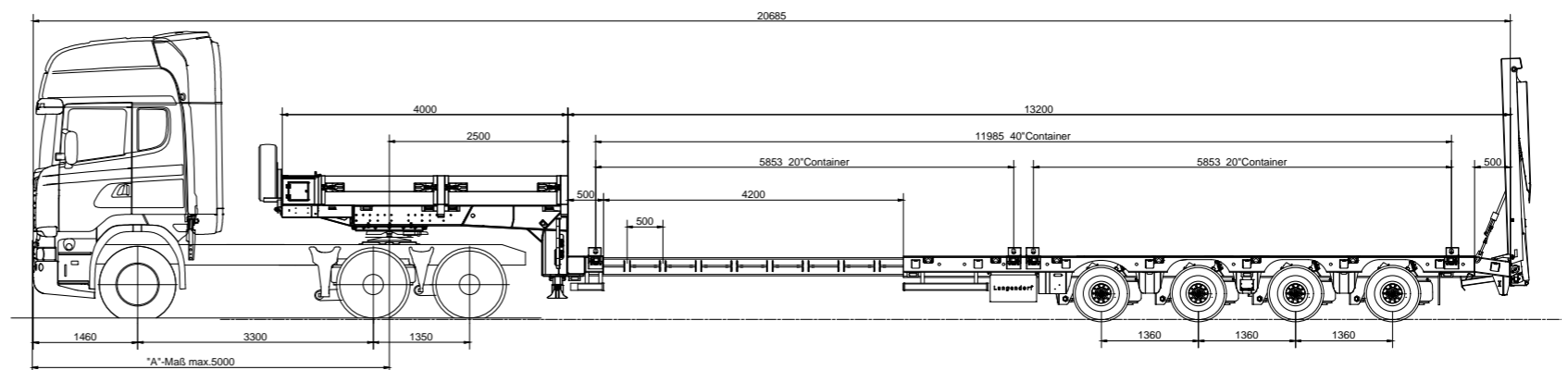

SATÜ-H 30

THE LOW LOADER TRAILER WITH HYDRAULIC RAMP BEHIND GOOSENECK, IDEAL FOR FORKLIFTS

Especially designed to transport access equipment or forklifts, with reinforcements to withstand the highest point loads.

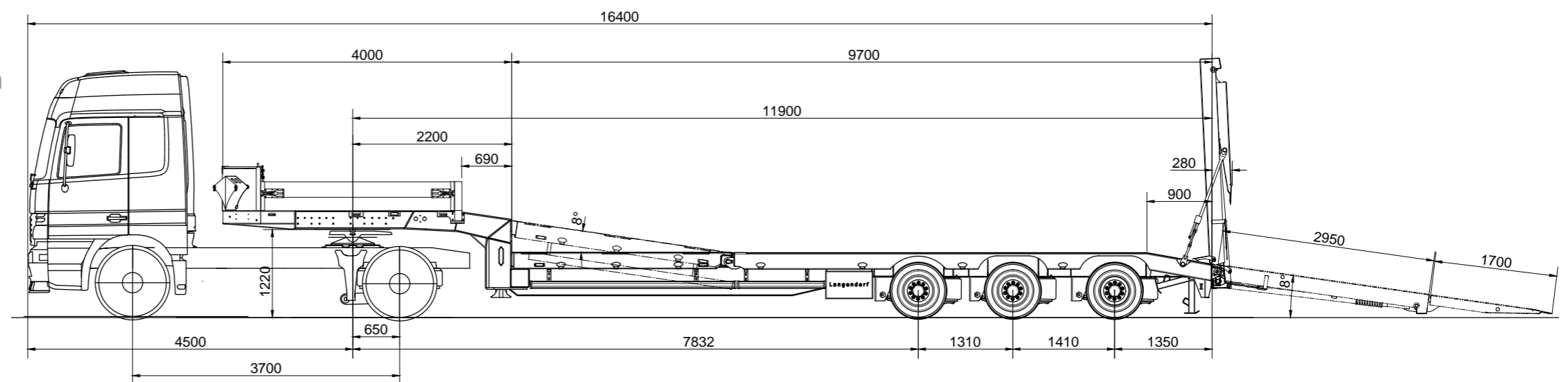

LOW LOADER TRAILER SATÜ 30 OPTIONS

Many options allow you to customize the trailer exactly to your transport needs.

You can pick from many options to adapt your trailer to the most complex machinery or goods.



LOW LOADER TRAILER SATAH

THE LOW LOADER WITH DEMOUNTABLE GOOSENECK

Ideal for smaller excavators or divided loads.

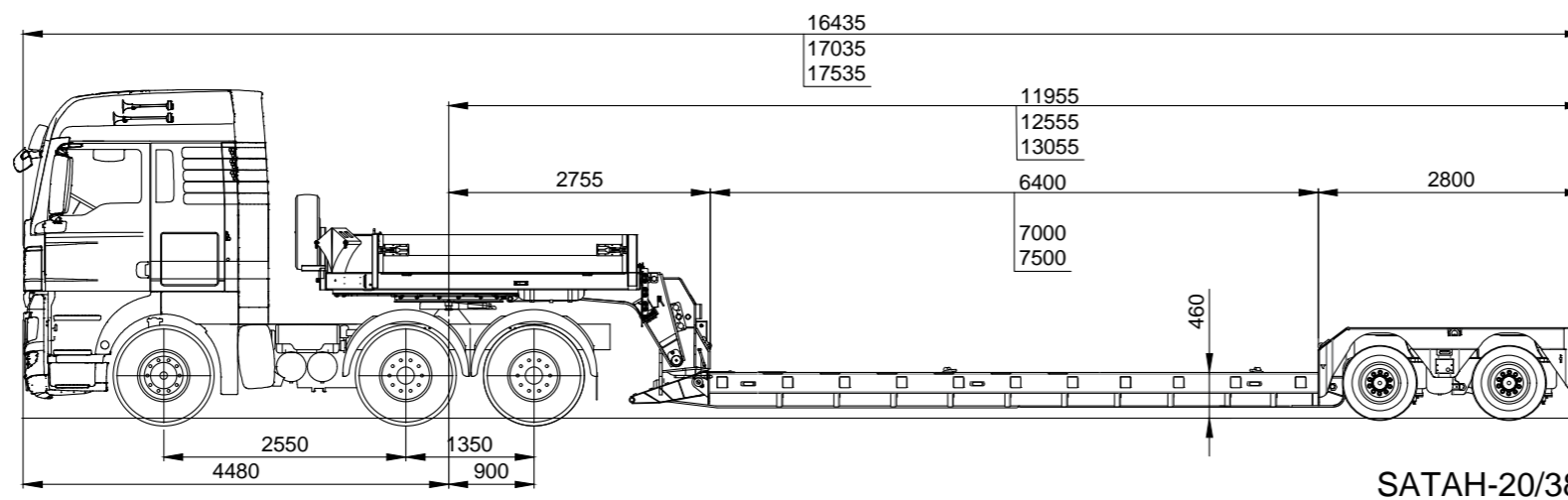

For heavy machinery, easy access from the front of the low bed by detaching the gooseneck.

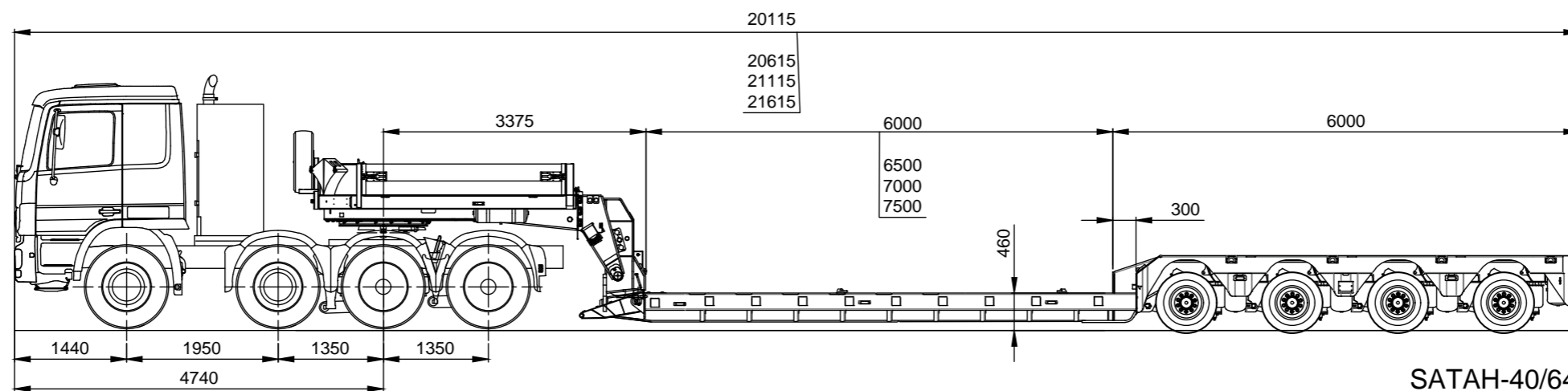

LOW LOADER TRAILER SATAHV

THE LOW LOADER WITH DETACHABLE GOOSENECK, EXTENDABLE

Lightweight version
to transport specialist
plant, including
forestry machines.

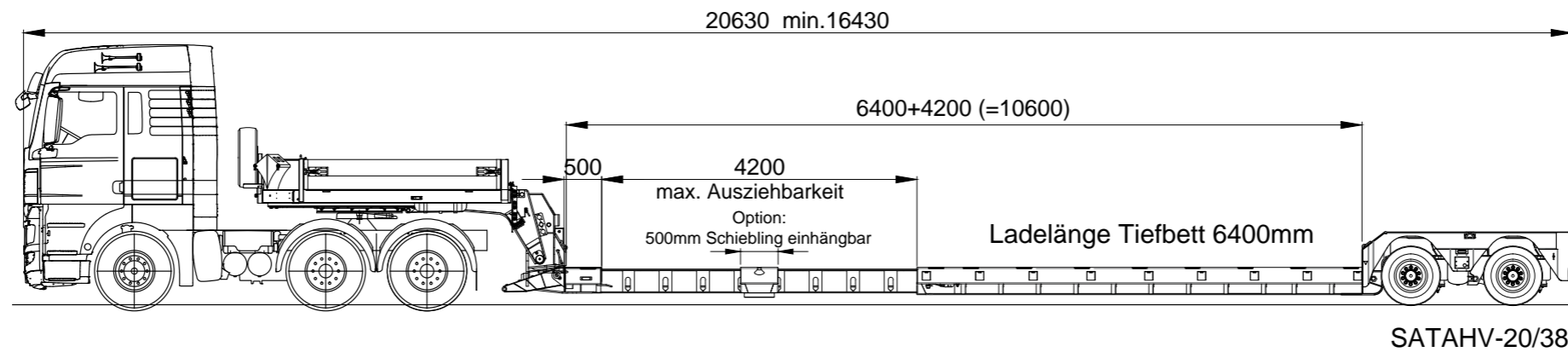

Heavy machinery,
such as crushers,
fit very well onto
this robust trailer.

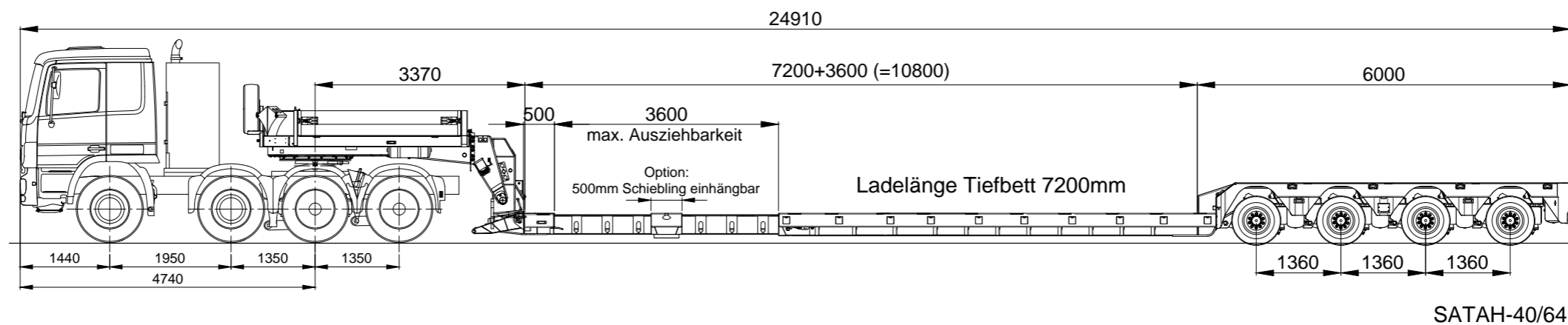

LOW LOADER TRAILER SATH

THE LOW LOADER WITH HYDRAULIC RAMP IN FRONT OF THE AXLES



For divided loads.

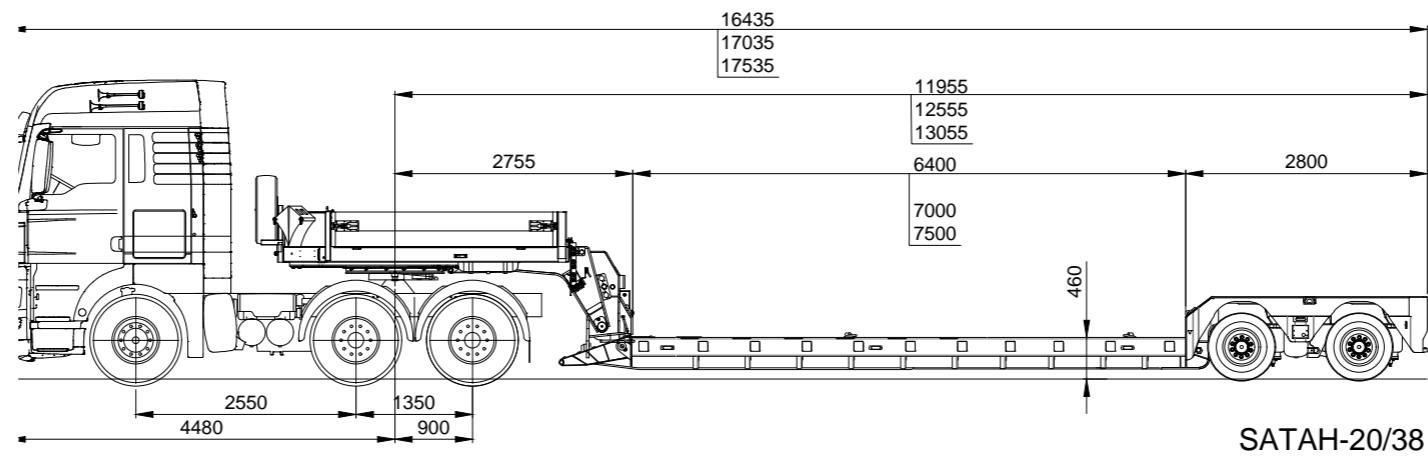

Perfect for almost every construction machine.

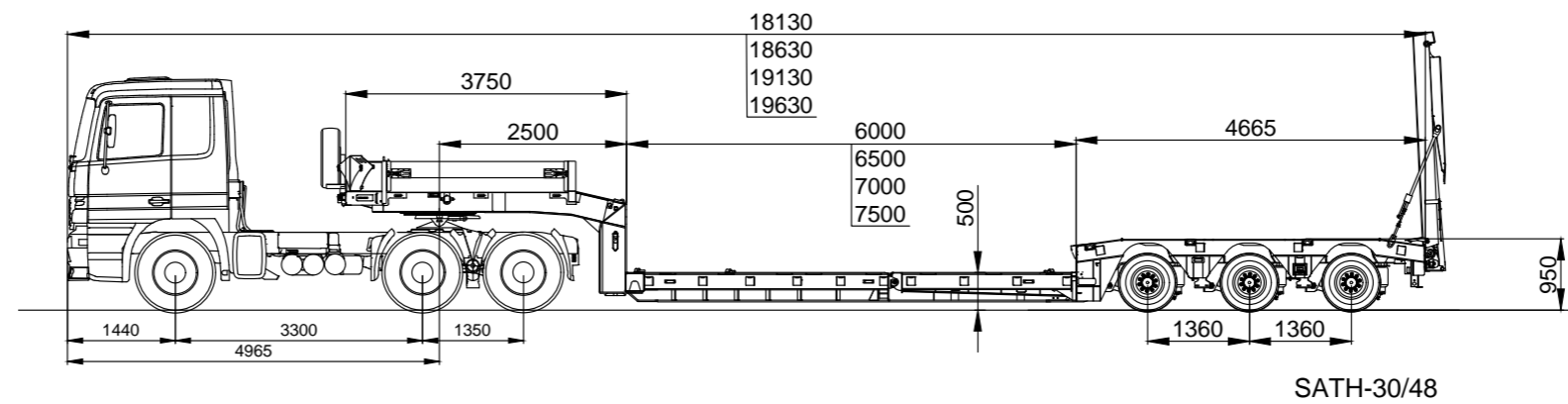

Even asphalt machines can easily access the trailer due to the machinery, such as crushers and easy access to the lowbed.

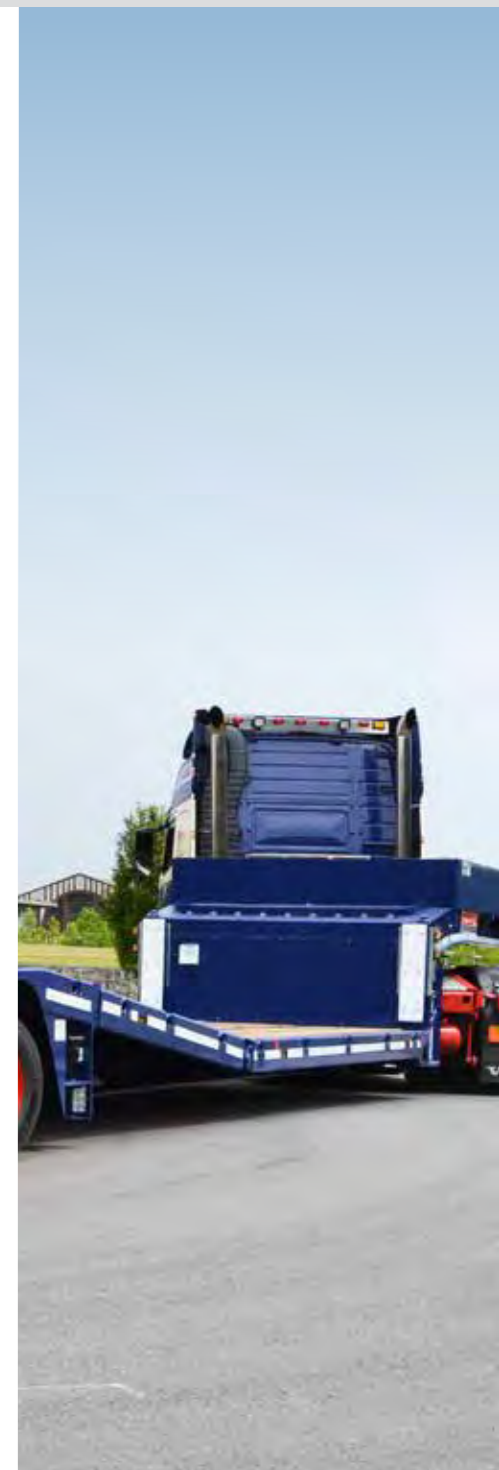
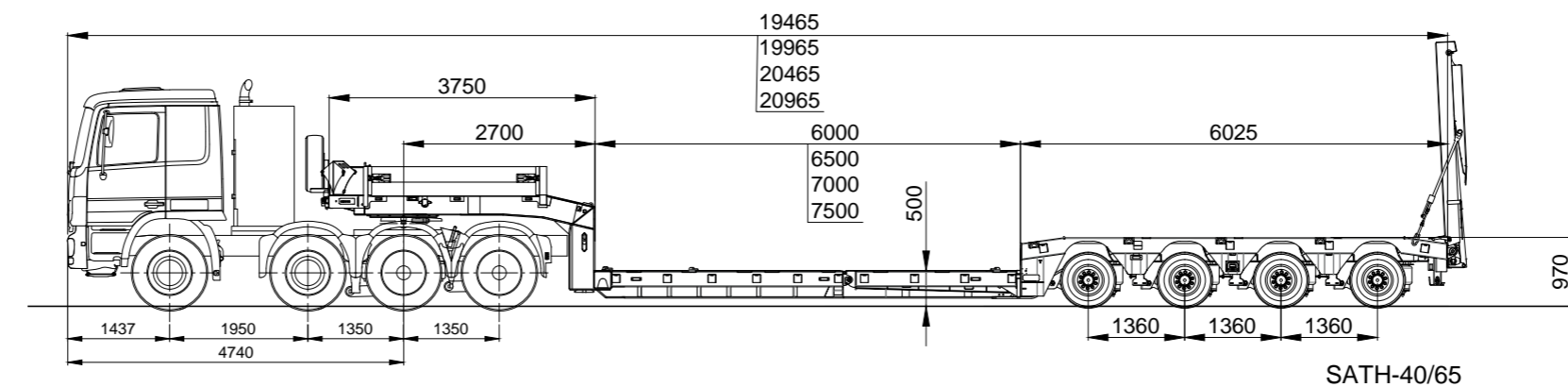

LOW LOADER TRAILER SATHV

With the same advantages as the SATH, but especially suited for long loads and machinery with a long jib.

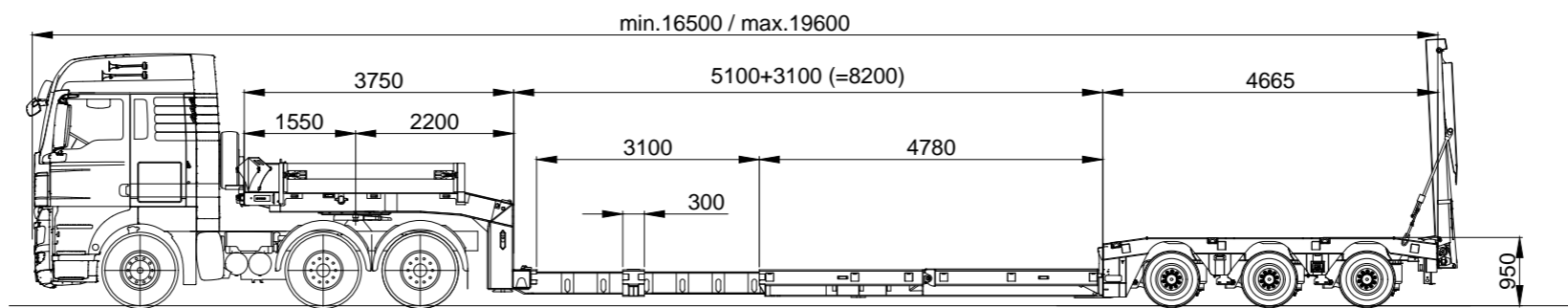
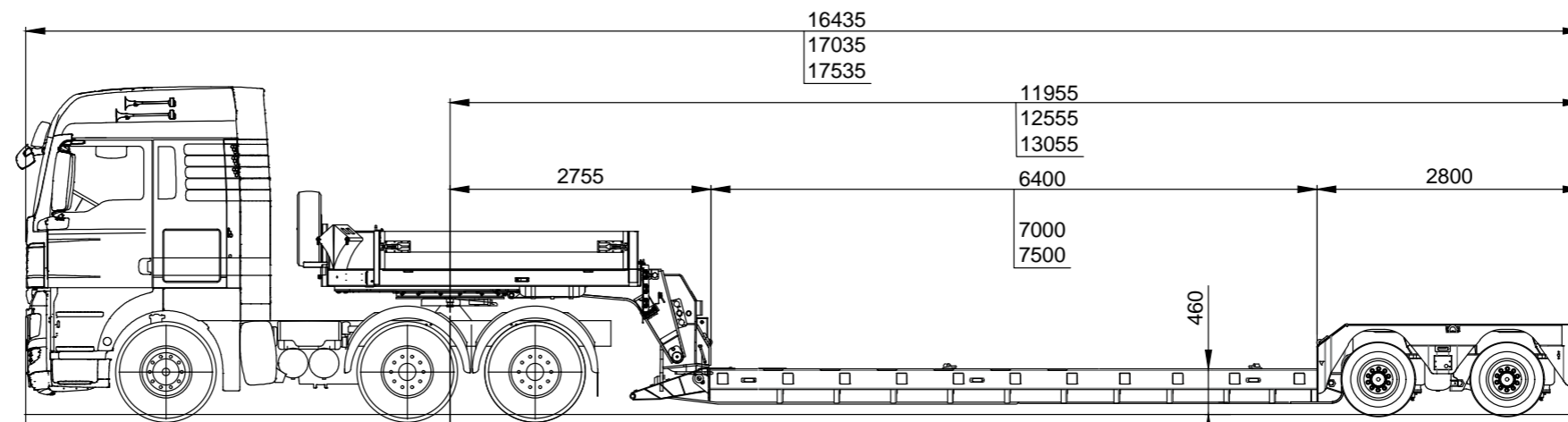

SATHV-30/46

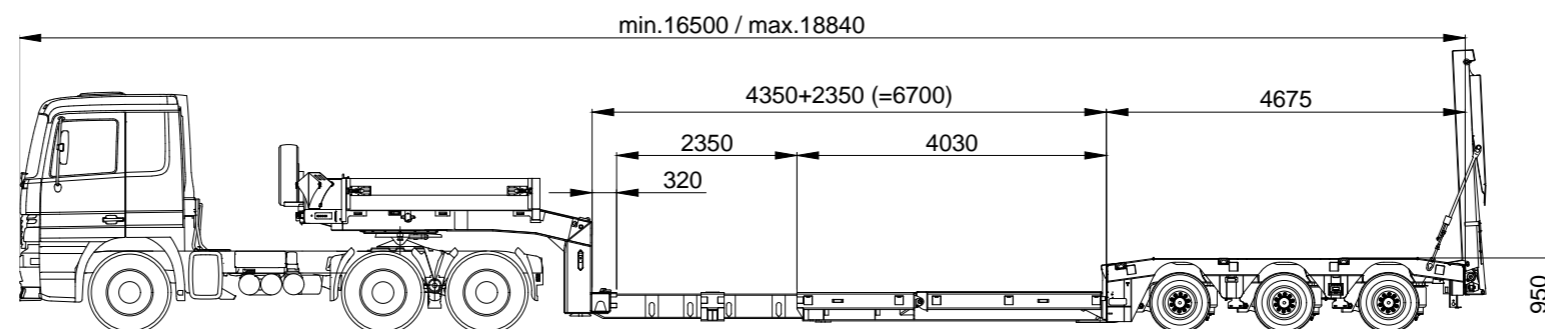

SATHV-30/48



LOW LOADER TRAILER SATBÜ THE CLASSIC LOW LOADER WITH FOLDABLE WEDGES IN FRONT OF THE AXLES



Perfect for tracked
construction machinery.
Height on floor only 500 mm.

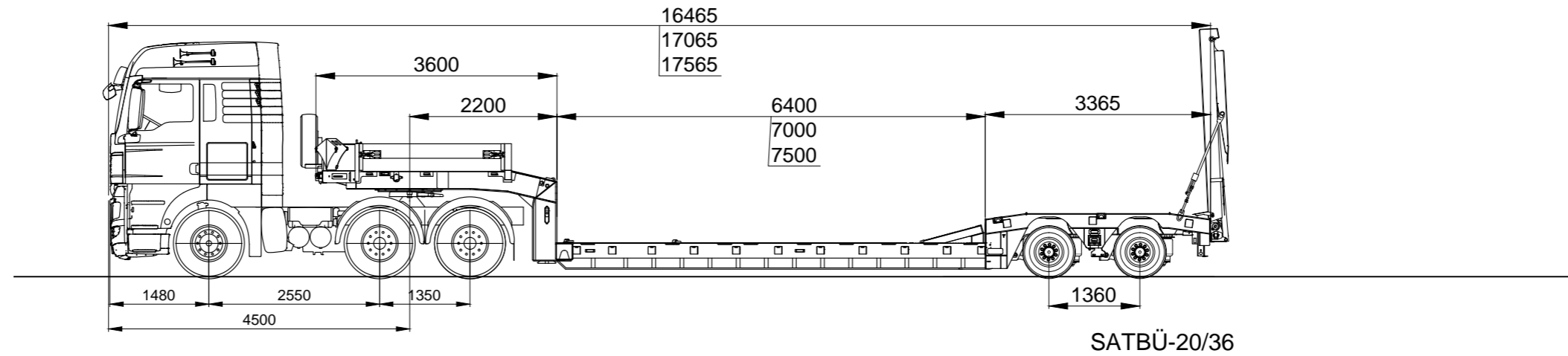

Same advantages, but
with a payload up to 45
tonnes.

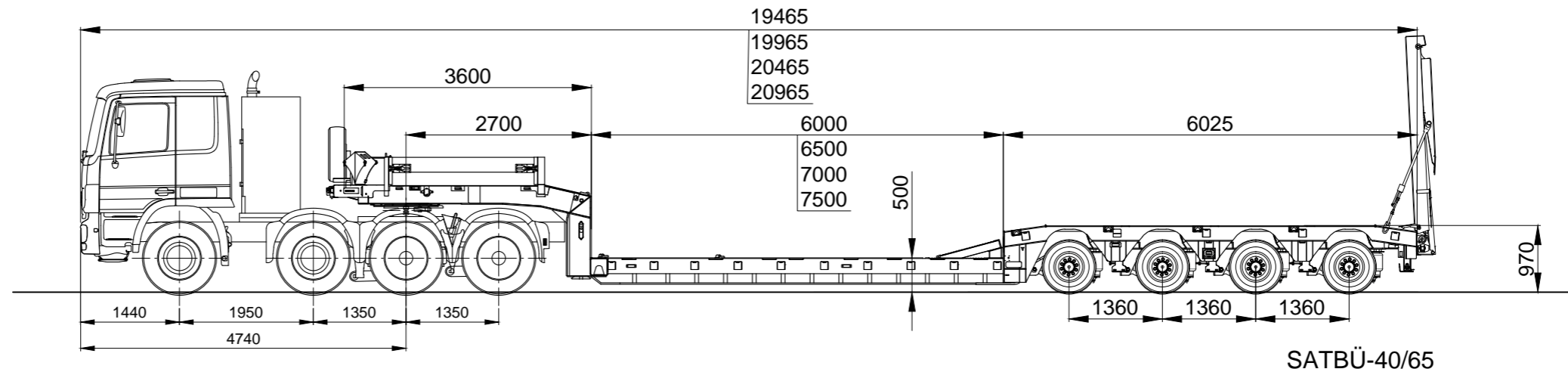

LOW LOADER TRAILER SATBÜ THE LOW LOADER WITH FOLDABLE WEDGES IN FRONT OF THE AXLES, EXTENDABLE



Even more payload than in the SATBH range because of the wedges instead of the hydraulic ramp.

What remains is the flexibility, the easy operation and the excellent payload carrying potential.

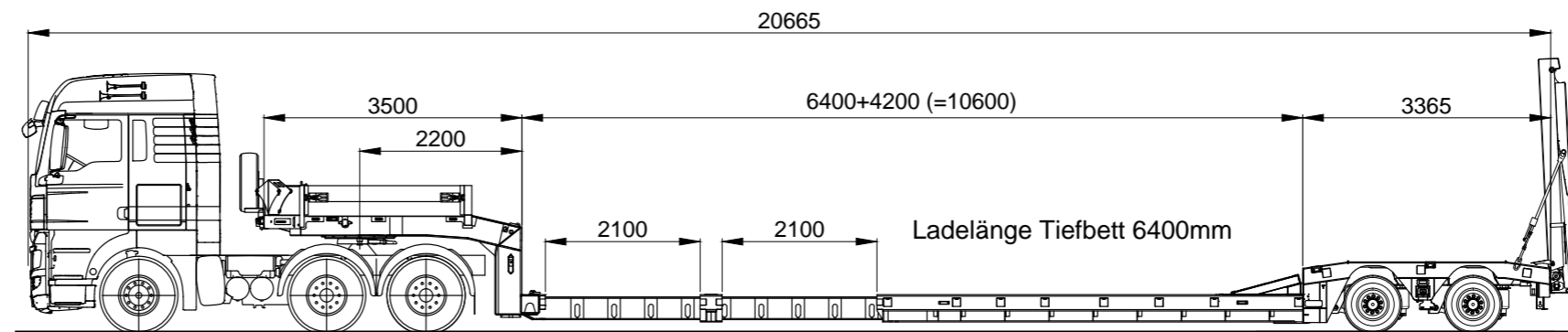

SATBÜV-30/46

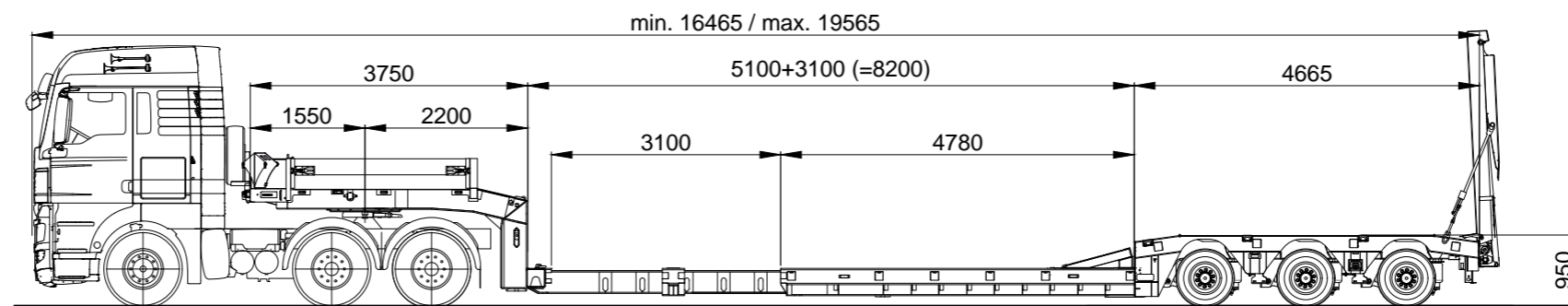

SATBÜV-30/46

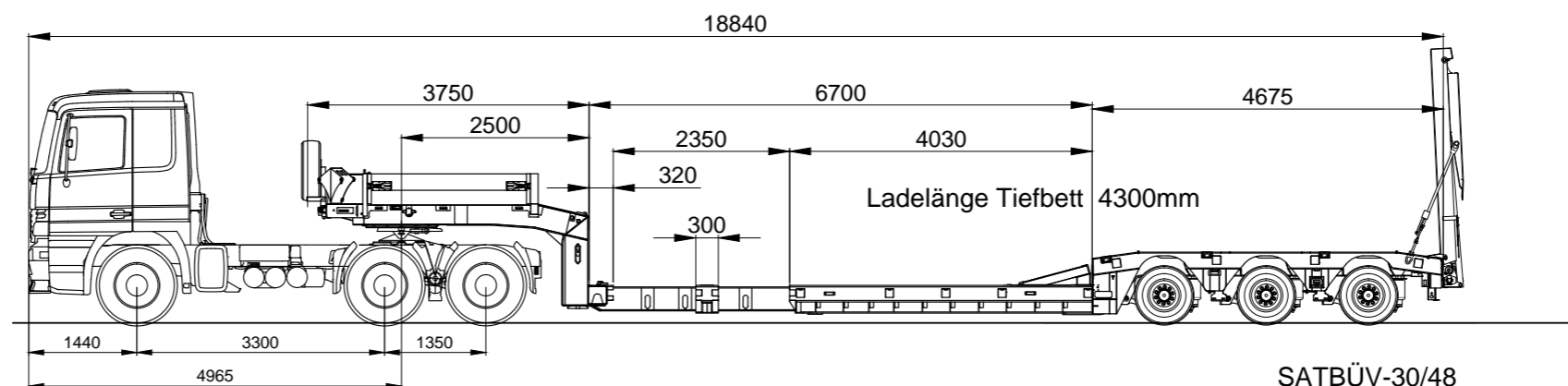

SATBÜV-30/48

LOW LOADER TRAILER FOR AGRICULTURAL MACHINERY. PERFECTLY ADAPTED, INDIVIDUAL DESIGN.

This model is adapted to the special needs for transporting agricultural machines. Many options are available to ensure operators can find the optimal solution for every transport.



WIDE RANGE OF RAMPS, TO SUIT ALL APPLICATIONS



We offer a wide range of ramp options: mechanical or hydraulic side shift, or spreading, with or without extra grip. Even the surface can be adapted for you: options include rubber, wood or grating. There is always a perfect solution.



OPTIONS AND ACCESSORIES. YOUR LOW LOAD TRAILER, AS INDIVIDUAL AS YOUR TRANSPORT.

Certified lashing rings, the Langendorf Vario-lashing system, bushings and stanchions, twist-locks, winches, extra lights, side extensions, toolboxes etc. The list of available options is endless.

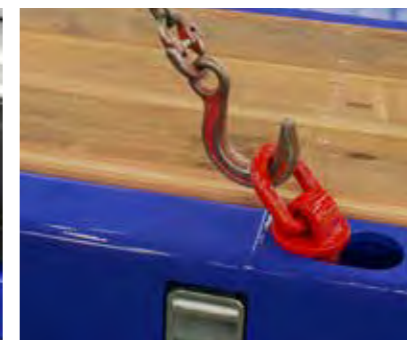

LOW LOADER TRAILERS BY LANGENDORF ALWAYS THE RIGHT CHOICE!

We have been manufacturing low loaders since 1956. Each one is custom-built, robust and engineered to deliver benefits to your business every day.

For professionals, by professionals!



VEHICLES BY LANGENDORF ON THE ROAD ON ALL CONTINENTS

Our bodies and trailers enjoy a particularly impressive reputation, and rightfully so. Key features inherent across our entire product range include the long service life, strong residual values and practical handling. Our engineers use state-of-the-art 3D-CAD systems to design and to construct new features, whilst always working hard to develop new production methods to optimise the Langendorf product range.

We are present at the leading commercial vehicle tradeshows, both in Germany and internationally, and we will gladly provide you interesting insights into our technical news and innovations.

The increasing international orientation, supported by the belonging to the Polish Wielton Group, reflected in expanded sales markets, globally successful customer relationships, licensing agreements the appointment of official agents to represent Langendorf in other countries.

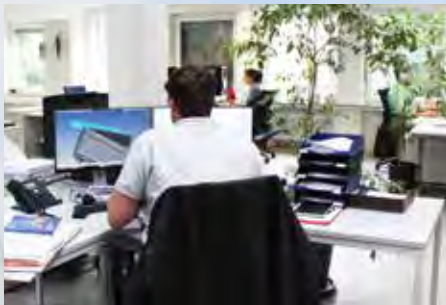

PRODUCTS BY LANGENDORF

- Tipper
- Inloaders
- Low-loaders
- Special vehicles



LD_18_00335_07/2018_GB Pictures include optional equipment. Changes are possible because of technical progress.



LANGENDORF GMBH · Bahnhofstraße 115 · 45731 Waltrop · GERMANY
☎ +49 2309 / 938-0 · 📠 +49 2309 / 938-190 · ✉ info@langendorf.de

**WIELTON
GROUP**